

MAHLE

Industrial Filtration

Low Pressure Filter

Pi 230

Nominal pressure 25/40 bar, (360/570 psi), nominal size up to 1400

1. Features

High performance filters for modern hydraulic systems

- Provided for pipe installation
- Modular system
- Compact design
- Minimal pressure drop through optimal flow design
- Visual/electrical/electronic maintenance indicator
- Quality filters, easy to service
- Equipped with highly efficient glass fibre Sm-x filter elements
- Beta rated elements according to ISO 16889 multipass test
- Elements with high differential pressure stability and dirt holding capacity
- Worldwide distribution



2. Flow rates/pressure drop curve (filter housing incl. element)

■ 190 mm²/s
■ 33 mm²/s

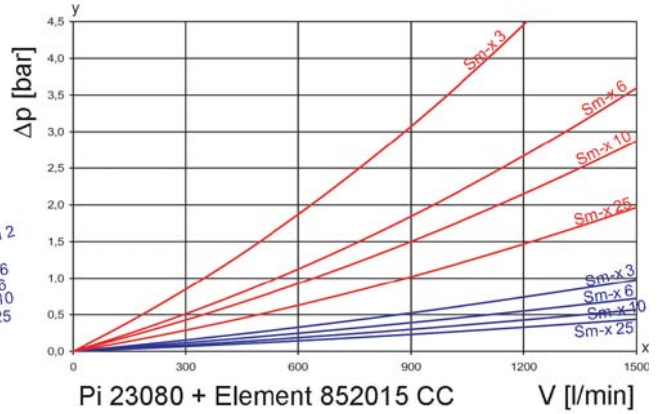
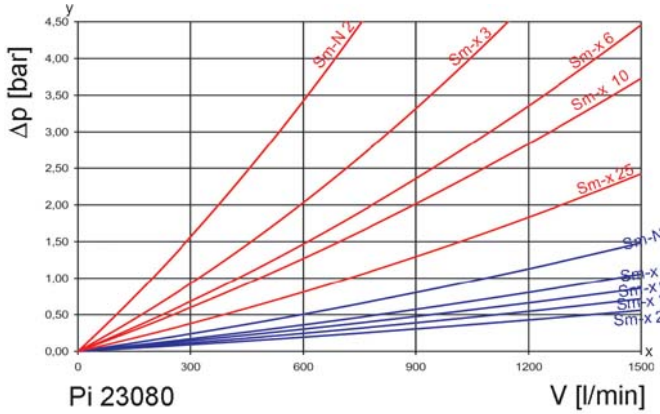
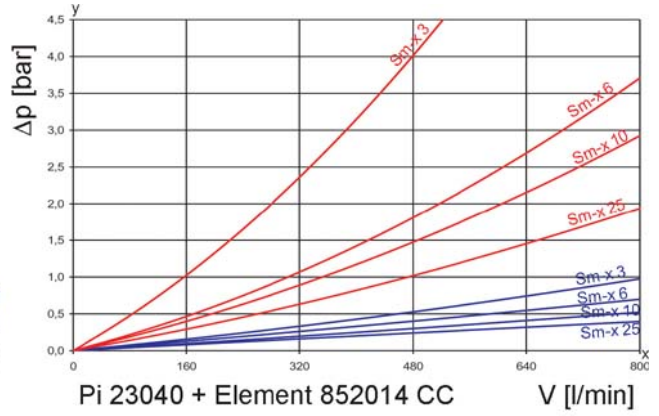
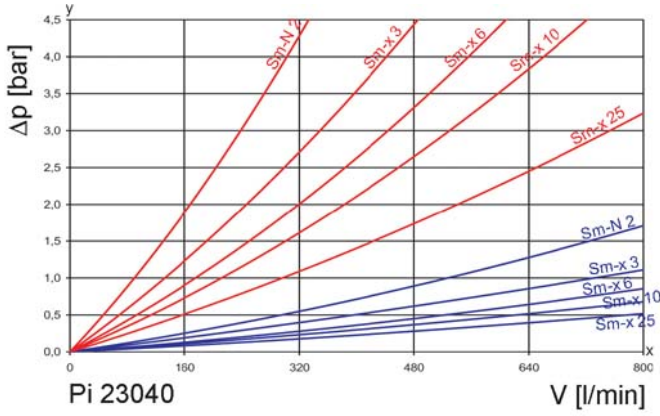

y = differential pressure Δp [bar]
 x = flow rate V [l/min]

3. Separation grade characteristics

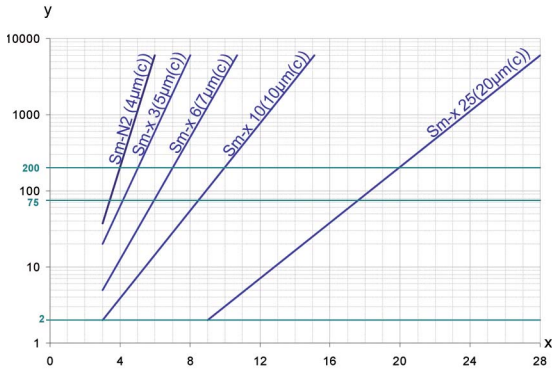

y = beta-value
x = particle size [µm]

determined by multipass tests (ISO 16889)
calibration according to ISO 11171 (NIST)

4. Filter performance data

tested according to ISO 16889 (multipass test)

Sm-x elements with
max. Δp 20 bar

Sm-x	3	$\beta_{5(C)} \geq 200$
Sm-x	6	$\beta_{7(C)} \geq 200$
Sm-x	10	$\beta_{10(C)} \geq 200$
Sm-x	16	$\beta_{15(C)} \geq 200$
Sm-x	25	$\beta_{20(C)} \geq 200$

values guaranteed up to
10 bar differential pressure

5. Quality assurance

MAHLE filters and filter elements are produced according to the following international standards:

Norm	Designation
DIN ISO 2941	Hydraulic fluid power filter elements; verification of collapse/burst resistance
DIN ISO 2942	Hydraulic fluid power filter elements; verification of fabrication integrity
DIN ISO 2943	Hydraulic fluid power filter elements; verification of material compatibility with fluids
DIN ISO 3723	Hydraulic fluid power filter elements; method for end load test
DIN ISO 3724	Hydraulic fluid power elements; verification of flow fatigue characteristics
ISO 3968	Hydraulic fluid power filters; evaluation of pressure drop versus flow characteristics
ISO 10771.1	Fatigue pressure testing of metal containing envelopes in hydraulic fluid applications
ISO 16889	Hydraulic fluid power filters; multipass method for evaluation filtration performance of a filter element

6. Symbols

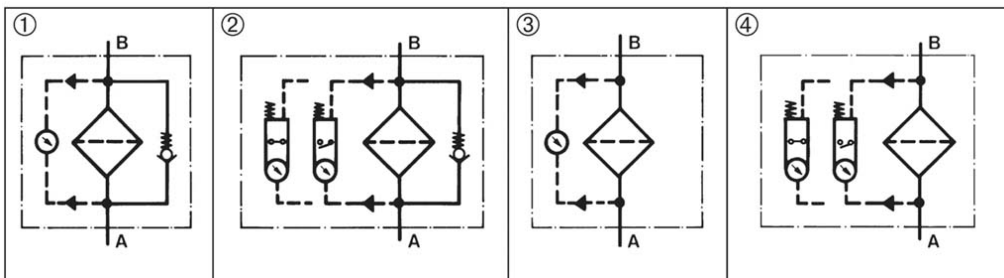

7. Order numbers

Example for ordering filters:

1. Filter housing	2. Filter element
Nominal size: 800, with bypass, electrical maintenance indicator, inlet at the side for standard filter elements Type: Pi 23040 / 22-058 Order number: 76320972	Sm-x 10 Type: Pi 852014 SM-x 10 Order number: 76321814

7.1 Housing design standard

Nominal size NG [l/min]	Order number inlet at the bottom	Type inlet at the bottom	Order number inlet at the side	Type inlet at the side	①	②	③	④
					with bypass valve and visual indicator	with bypass valve and electrical indicator	with visual indicator	with electrical indicator
800	76334668	Pi 23040/12-057	76320931	Pi 23040/22-057				
	76320964	Pi 23040/12-058	76320972	Pi 23040/22-058				
	76321004	Pi 23040/12-068	76321012	Pi 23040/22-068				
	76321046	Pi 23040/12-069	76321053	Pi 23040/22-069				
1400	76320949	Pi 23080/12-057	76320956	Pi 23080/22-057				
	76320980	Pi 23080/12-058	76320998	Pi 23080/22-058				
	76321020	Pi 23080/12-068	76321038	Pi 23080/22-068				
	76321061	Pi 23080/12-069	76321079	Pi 23080/22-069				

When filter with non bypass configuration is selected, the collapse pressure of the element must not be exceeded.

7.2 Filter elements standard*

Nominal size NG [l/min]	Order number	Type	Filter material	max. Δp [bar]	Filter surface [cm ²]
800	76136220	852014 Sm-N 2	Sm-N 2	20	18533
	76321830	852014 Sm-x 3	Sm-x 3		24830
	76321822	852014 Sm-x 6	Sm-x 6		24830
	76321814	852014 Sm-x 10	Sm-x 10		24830
	76321806	852014 Sm-x 25	Sm-x 25		24830
1400	76136212	852015 Sm-N 2	Sm-N 2	20	42275
	76321897	852015 Sm-x 3	Sm-x 3		57200
	76321889	852015 Sm-x 6	Sm-x 6		57200
	76321871	852015 Sm-x 10	Sm-x 10		57200
	76321863	852015 Sm-x 25	Sm-x 25		57200

* a wider range of element types is available on request

7.3 Housing design CC

Nominal size NG [l/min]	Order number inlet at the bottom	Type inlet at the bottom	Order number inlet at the side	Type inlet at the side	①	②	③	④
					with bypass valve and visual indicator	with bypass valve and electrical indicator	with visual indicator	with electrical indicator
800	79770074	Pi 23040/1C-057	79770116	Pi 23040/2C-057				
	76320642	Pi 23040/1C-058	76320659	Pi 23040/2C-058				
	76320683	Pi 23040/1C-068	76320691	Pi 23040/2C-068				
	76320725	Pi 23040/1C-069	76320733	Pi 23040/2C-069				
1400	79768854	Pi 23080/1C-057	79768862	Pi 23080/2C-057				
	76320667	Pi 23080/1C-058	76320675	Pi 23080/2C-058				
	76320709	Pi 23080/1C-068	76320717	Pi 23080/2C-068				
	76320741	Pi 23080/1C-069	76320758	Pi 23080/2C-069				

When filter with non bypass configuration is selected, the collapse pressure of the element must not be exceeded.

7.4 Filter elements CC*

Nominal size NG [l/min]	Order number	Type	Filter material	max. Δp [bar]	Filter surface [cm ²]
800	76135859	852014 CC Sm-x 3	Sm-x 3	5	23000
	76135867	852014 CC Sm-x 6	Sm-x 6		23000
	76135875	852014 CC Sm-x 10	Sm-x 10		23000
	76135883	852014 CC Sm-x 25	Sm-x 25		23000
1400	76322028	852015 CC Sm-x 3	Sm-x 3	5	60159
	76322010	852015 CC Sm-x 6	Sm-x 6		60159
	76322002	852015 CC Sm-x 10	Sm-x 10		60159
	76321996	852015 CC Sm-x 25	Sm-x 25		60159

* a wider range of element types is available on request

8. Technical specifications

Nominal pressure (10 ⁷ LW):	25 bar (360 psi)
Nominal pressure (static):	40 bar (570 psi)
Temperature range:	-10 °C to +120 °C (other temperature ranges on request)
Bypass setting:	Δ 3.5 bar ± 10 %
Filter head and cap material:	GAL
Filter housing material:	AL
Sealing material:	NBR
Maintenance indicator setting:	Δ p 2.2 bar ± 0.3 bar
Electrical data of maintenance indicator:	
Maximum voltage:	250 V AC/200 V DC
Maximum current :	1 A
Contact load:	70 W
Type of protection:	IP 65 in inserted and secured status
Contact:	normally open/closed
Cable connection:	M20x1.5

The switching function can be changed by turning the electric upper part by 180 ° (normally closed contact or normally open contact). The state on delivery is normally closed contact. By inductivity in the direct current circuit the use of suitable protection circuit should be considered. Further maintenance indicator details and designs are available in the maintenance indicator data sheet.

We draw attention to the fact that all values indicated are average values which do not always occur in specific cases of application. Our products are continually being further developed. Values, dimensions and weights can change as a result of this. Our specialized department will be pleased to offer you advice.

We recommend you to contact us concerning applications of our filters in areas governed by the EU Directive 94/4 EC (ATEX 95). The standard version can be used for liquids based on mineral oil (corresponding to fluids in Group2 of Directive 97/23 EC Article 9). If you consider to use other fluids please contact us for additional support.

Subject to technical alteration without prior notice.

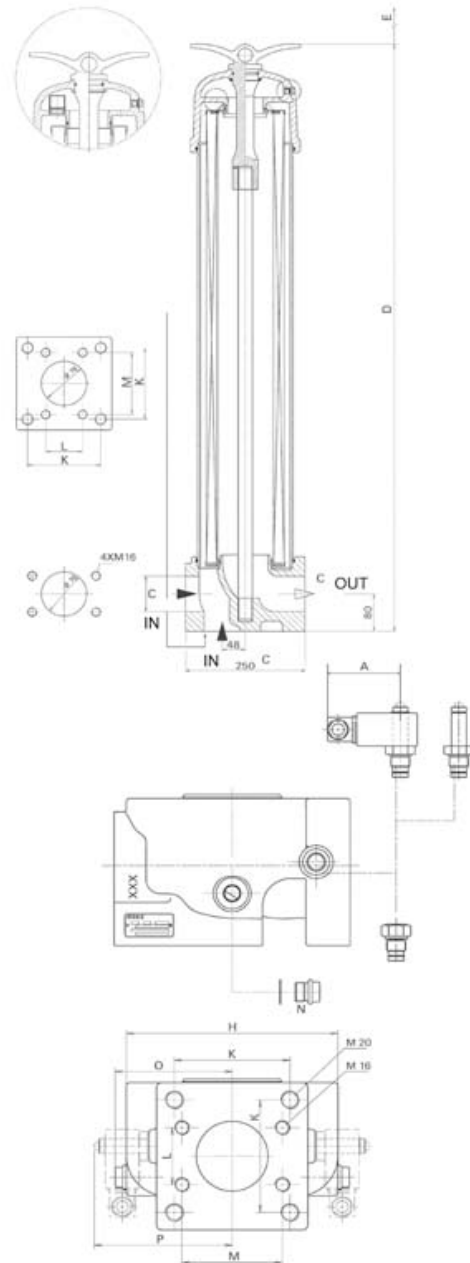

9. Dimensions

All dimensions except "C" and "N" in mm.

Type	A	B	C	D	E	F	G	H
Pi 23040	78	80	SAE 3", 3000 psi	710	770	230	200	224
Pi 23080	78	80	SAE 3", 3000 psi	1260	770	230	200	224

Type	I	K	L	M	N	O	P	Weight [kg]
Pi 23040	250	122.3	61.9	106.6	G½	124	146	29
Pi 23080	250	122.3	61.9	106.6	G½	124	146	38

NPT- and SAE-connections on request.

10. Installation, operating and maintenance instructions

10.1 Filter installation

When installing filter make sure that sufficient space is available to remove spin-on cartridge. Preferably the filter should be installed with the filter housing pointing upwards.

The maintenance indicator must be visible.

10.2 Connecting the electrical maintenance indicator

The electrical indicator is connected via a 2-pole appliance plug according to DIN EN 175301-803 with poles marked 1 and 2. The electrical section can be inverted to change from normally open to normally closed position or vice versa.

10.3 When should the filter element be replaced?

- Filters equipped with visual and electrical maintenance indicator:
During cold starts, the indicator may give a warning signal. Press the red button of the visual indicator once again and only after operating temperature has been reached. If the red button immediately pops up again and/or the electrical signal has not switched off after reaching operating temperature, the spin-on cartridge must be replaced after the end of the shift.
- Filters without maintenance indicator:
The filter element should be replaced after the trial run or flushing of the system. Afterwards follow the instructions of the manufacturer.
- Please always ensure that you have original MAHLE spare elements in stock: Disposable elements (Sm-x, Sm-N) cannot be cleaned.

10.4. Element replacement

- Stop system and relieve filter from pressure.
- Loosen quick-action clamp, remove cover and open drain valve. Housing completely vented.
- Remove filter element from filter housing.
- Check seals for damages. Replace, if necessary.
- Make sure that the order number on the spare element corresponds to the order number of the filter name-plate.
To ensure no contamination occurs during the exchange of the element first open the plastic bag and push the element over the spigot in the filter head. Now remove plastic bag.
- Close drain valve. Put the thumb screw together with the cover on the centre rod and tighten strong. Filter must be bled.

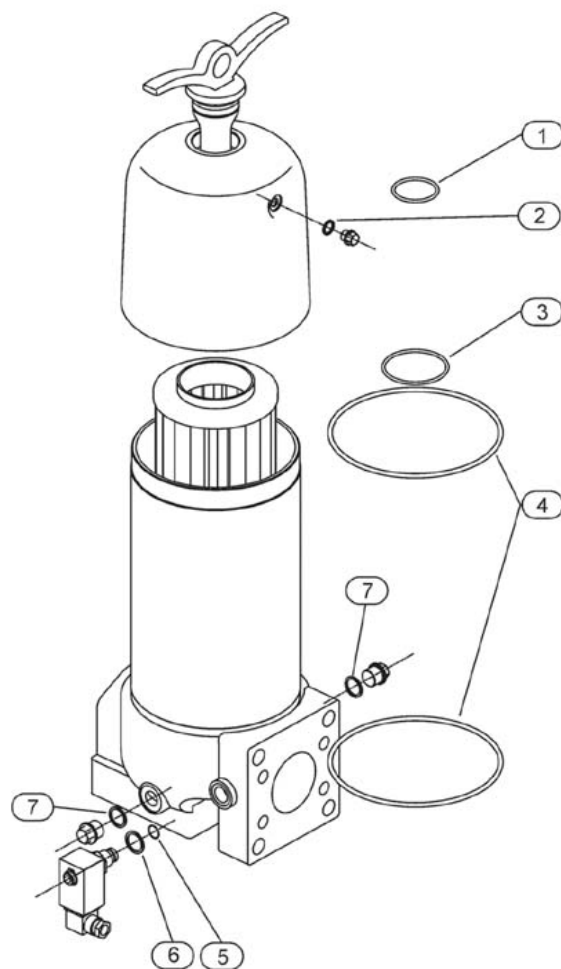

11. Spare parts list

Order numbers for spare parts		
Position	Type	Order number
① ② ③ ④ ⑦	Seal kit	
	NBR	76321244
	FPM	76321251
	EPDM	76321269
	Maintenance indicator	
	Visual PiS 3098/2.2	77669971
	Visual/electrical PiS 3097/2.2	77669948
	Electrical upper section only	77536550
⑤ ⑥	Seal kit for maintenance indicator	
	NBR	77760309
	FPM	77760317
	EPDM	77760325

MAHLE

Industrial Filtration

MAHLE Filtersysteme GmbH
Industriefiltration
Schleifbachweg 45
D-74613 Öhringen
Phone +49 (0) 794/67-0
Fax +49 (0) 7941/67- 23429
industriefiltration@mahle.com
www.mahle-industriefiltration.com
76349484.04/2009